

Signal Extraction Technology®

INTRODUCTION

Masimo SET® pulse oximetry is a new and fundamentally distinct method of acquiring, processing and reporting arterial oxygen saturation and pulse rate. As illustrated below, Masimo SET technology enables the power of adaptive filters to be applied to real-time physiologic monitoring by utilizing proprietary techniques to accurately establish a “noise reference” in the detected physiologic signal, thus enabling the direct calculation of arterial oxygen saturation and pulse rate. Because it is not bound by a conventional “red over infrared” ratio approach, the Masimo SET system substantially eliminates the problems of motion artifact, low peripheral perfusion and most low signal-to-noise situations. This greatly extends the utility of SpO₂ in high motion, low signal and noise intensive environments.

The superior performance of Masimo SET pulse oximetry has been clinically validated. The graphs below summarizes the results of one such study.

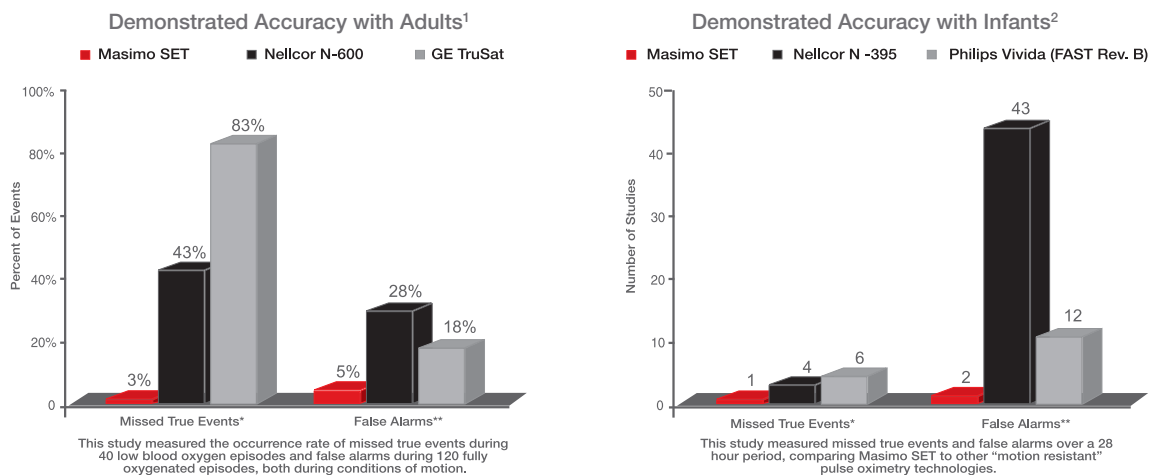

* The failure of the monitor to detect a physiological change that should trigger the monitor's alarm.

** The erroneous activation of the monitor's alarm without an appropriate triggering physiological event.

¹ Shah N, Estanol L. Comparison of three new generation pulse oximeters during motion & low perfusion in volunteers. *Anesthesiology*. 2006; 105: A929.

² Hay WW, Rodden DJ, Collins SM, Melara DL, Hale KA, Fashaw LM. Reliability of conventional and new oximetry in neonatal patients. *Journal of Perinatology*. 2002; 22:360-366.

Discrete Saturation Transformation (DST®) Algorithm

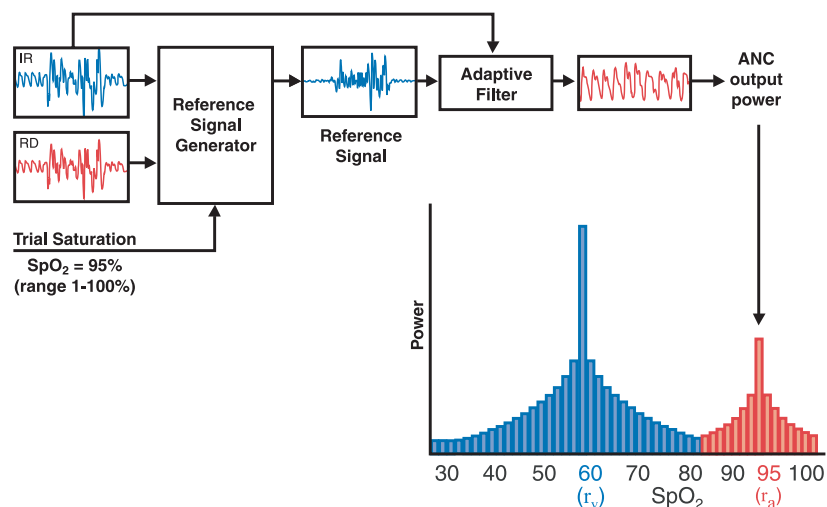

Masimo SET's most powerful algorithm is DST. All algorithms depend upon assumptions. The more assumptions, the weaker the algorithm. DST makes only one assumption - that arterial blood has a higher oxygenation than venous - making it the most powerful pulse oximetry algorithm.

CONVENTIONAL FILTERS

While pulse oximetry is readily accepted as a standard of care in the Operating Room, Recovery Room and most Intensive Care Units¹, its performance in high motion environments or in patients with low perfusion is substantially less than ideal. The reported high incidence of false alarms due to motion artifact² and the inability of conventional pulse oximetry systems to provide information during times of crisis have led to its characterization as a "fair weather friend."³ Confronted with the problem of motion artifact, false alarms and poor "signal to noise" environments, medical equipment manufacturers have utilized band-pass filtering in an attempt to address these confounding clinical problems. Band-pass filters, whether in analog or digital form, are designed to allow only a physiologic window of interest to pass while rejecting frequencies outside the desired frequency band. With the advent of Digital Signal Processing (Digital Filtering), the performance of band-pass filtering was improved, but was still unable to address the problem of noise occurring within the bandwidth of interest.

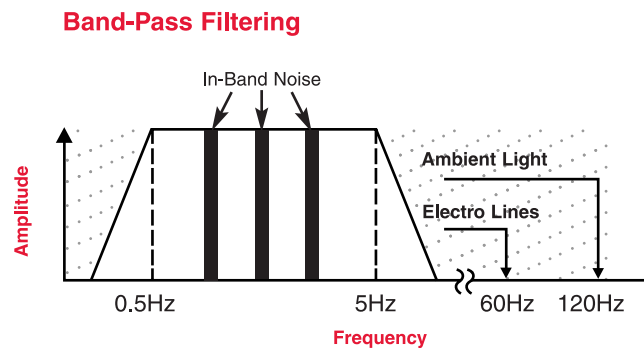

ADAPTIVE FILTERS

To address the confounding issue of "in-band" noise, a class of filters known as adaptive digital filters has evolved. These filters take advantage of the fact that the construction of the filter itself is contained within the memory of the microprocessor, allowing its multiplication coefficients, symbolized as W_0, W_1, \dots, W_{n-1} , to be changed in real time, hence altering the filter's characteristic. Thus, the filter can be tuned "on the fly." The multiplication coefficients determine whether the frequency components of an input signal should be cancelled (e.g., multiplied by zero) or allowed to pass (e.g., multiplied by one). Given that the filter's coefficients can be rapidly changed, adaptive filters derive their name in their ability to change their filtering characteristics in response to changing in-band noise.

The detected physiologic signal is generally composed of both desired signal (S) and undesired signal (N) or noise portions. To remove the effects of the undesired signal, some knowledge of the noise characteristics, or equivalently its noise reference (N'), must be known. The adaptive filter will adjust its filtering characteristics, so that the noise reference input is transformed into an estimate of the undesired signal portion (\hat{N}) of the physiologic signal. A subtractor subsequently removes the undesired signal from the physiologic signal to yield an estimate of the desired signal portion (\hat{S}). The combination comprising the adaptive filter and the subtractor is commonly called an adaptive noise canceller (ANC).

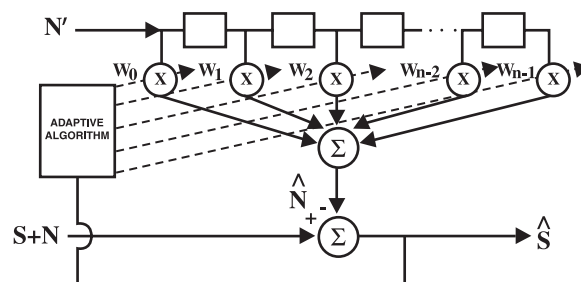

Adaptive Noise Canceller (ANC) block diagram

This approach has been widely used in the telecommunications and aerospace industries where a suitable noise reference is accessible. Probes are utilized to obtain a noise reference that can then be used in conjunction with an adaptive noise canceller to extract a desired signal portion from a composite signal containing both desired and undesired signal portions. The problem in applying this technique to physiological monitoring is that a noise reference is rarely available. In addition, both the noise and the desired signal vary from patient to patient and are quickly and continually changing in terms of frequency, amplitude and phase, even within the same patient. In pulse oximetry, the noise reference signal required to make an adaptive noise canceller work in real time was unavailable until the advent of Masimo Signal Extraction Technology.

CONVENTIONAL PULSE OXIMETRY

The conventional "red over infrared" approach measures the differential optical density of red (o) and infrared (I_{ir}) light as projected through a vascular bed and calculates a ratio (r) of the optical densities. Utilizing the optical density ratio, an arterial oxygen saturation (SpO₂) value is empirically reported based on the ratio obtained.

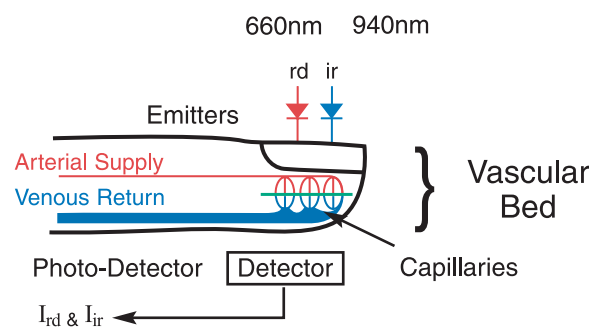

Basis For Measurement:

$$\frac{I_{rd}}{I_{ir}} = \frac{S_{rd} + N_{rd}}{S_{ir} + N_{ir}} = \text{Ratio } (r) \rightarrow \% \text{ SpO}_2$$

In the presence of patient motion, the optical densities of red and infrared light contain noise portions (N_{rd}, N_{ir}), thereby falsely altering the optical density ratio and providing an inaccurate saturation value. During periods of routine patient motion or low perfusion, the noise components within the physiologic signals can be much larger than the desired signals (S_{rd}, S_{ir}). In these cases, the optical density ratio is primarily determined by the noise contributions. This represents a situation whereby the noise is simply "drowning out" the desired signal.

In a large noise environment, conventional wisdom holds that pulse oximetry will yield an optical density ratio substantially equivalent to "noise over noise" or a ratio of one. This is equivalent to a saturation value of approximately 82% in most conventional systems.

If: $N \gg S$,

$$\text{Then: } \frac{I_{rd}}{I_{ir}} = \frac{N_{rd}}{N_{ir}} \cong 1 \rightarrow 82\% \text{ SpO}_2$$

Confronted with the problems of overwhelming noise and prevented from utilizing adaptive digital filters, pulse oximetry manufacturers have resorted to "managing" false alarms. This can include extending averaging times or employing a decision matrix to freeze when it decides it has detected motion. If the motion persists, it reports zero.⁴

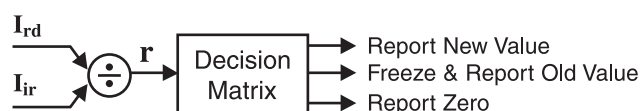

The attempt to treat the "symptom" rather than the "core problem" does not provide clinicians with continuous real-time information and can be unreliable in critical medical situations.

MASIMO SET® PULSE OXIMETRY

Masimo Signal Extraction Technology rejects the conventional wisdom and begins with an understanding that during patient motion the venous blood, being at a relatively low pressure, is quite susceptible to the local effects of perturbation during motion. Considering the finger for example, the venous blood in the vascular bed will be easily deformed during motion, representing a significant source of in-band noise within the frequency bandwidth of interest. In addition, the venous blood is a strong absorber of light. Hence, it can represent a significant contributor to the total optical density during motion episodes. Furthermore, the venous blood saturation is normally lower than the arterial blood saturation. This explains why saturation values tend to drop in conventional pulse oximeter systems during episodes of patient motion.

During routine patient motions (shivering, waving, tapping, etc.), the resulting noise can be quite substantial and can easily overwhelm a conventional ratio based oximetry system. Having identified the venous blood as a significant contributor to noise during motion, it follows that if the noise reference corresponding to the venous component could be measured, then an adaptive noise canceller might be utilized to cancel its contribution.

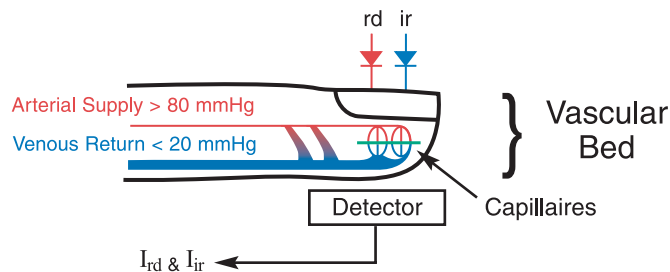

GENERATING A NOISE REFERENCE

The detected physiologic signals in response to both red (I_{rd}) and infrared (I_{ir}) light consist of desired signal portions (S_{rd}, S_{ir}) as well as undesired signal portions (N_{rd}, N_{ir}). It is commonly understood in pulse oximetry that the desired signal portions are proportional to one another through the arterial optical density ratio (r_a). This suggests that one should simply subtract the product of the arterial optical density ratio and the physiologic signal due to infrared light from the physiologic signal due to red light. The resultant is a reference signal that contains only noise portions. This is the noise reference signal (N')

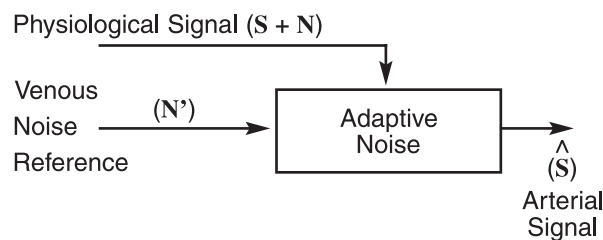

If the arterial optical density ratio is known, one can easily calculate the noise reference as just described. However, if it were known, one could simply calculate the arterial oxygen saturation directly. One would not need to utilize the adaptive noise cancellation process. How does one then use the power of adaptive filters and noise reference signals for pulse oximetry? The answer lies in the Discrete Saturation Transform® algorithm.

DISCRETE SATURATION TRANSFORM®

The Discrete Saturation Transform algorithm allows one to separate and, consequently, calculate the optical density ratios that correspond to both the arterial oxygen saturation (r_a) and an estimate of the venous oxygen saturation (r_v). These optical densities are not known beforehand but are required to obtain the appropriate reference signals for adaptive noise cancellation. Every optical density ratio, corresponding to the patient's physiological range ($SpO_2 = 1\%$ to 100%) must be considered. Therefore, the DST® algorithm not only uses a noise reference signal, but a whole family of reference signals. Each reference signal is used in the adaptive noise cancellation process and each yields information regarding the oxygen saturation content of the physiological signals.

<p>If:</p> <p>① $I_{rd} = S_{rd} + N_{rd}$</p> <p>② $I_{ir} = S_{ir} + N_{ir}$</p> <p>③ $r_a = \frac{S_{rd}}{S_{ir}}$</p> <p style="padding-left: 40px;">$S_{rd} = r_a \cdot S_{ir}$</p>	<p>Then:</p> <p>$I_{rd} - [I_{ir} \cdot r_a] = [S_{rd} + N_{rd}] - [S_{ir} r_a + N_{ir} r_a]$</p> <p>Substituting $S_{ir} r_a$ for S_{rd}, we get:</p> <p style="padding-left: 40px;">$= [S_{ir} r_a + N_{rd}] - [S_{ir} r_a + N_{ir} r_a]$</p> <p style="padding-left: 40px;">$= N_{rd} - N_{ir} r_a$</p> <p style="padding-left: 40px;">$= N'(\text{Noise Reference})$</p>
---	--

A family of reference signals, $N'(r)$, is generated similar to that of a noise reference signal. The reference signal, as discussed earlier, is the difference between the physiologic signal due to red light (I_{rd}) and the product of an arbitrary optical density ratio (r) and the physiologic signal due to infrared light (I_{ir}). Although there is a family of reference signals, based on the selected optical density ratio, there are only three distinct cases to consider. If one selects an optical density ratio that does not correspond to either arterial or venous oxygen saturation (Case I), the reference signal consists of a desired signal portion and an undesired signal portion. In the adaptive noise cancellation process, such a signal will not only remove the undesired signal portions of the physiologic signal, but also remove the desired signal portions. When an optical density ratio that corresponds to the venous oxygen saturation is selected (Case II), the reference signal only contains signal portions. Therefore, the output of the adaptive noise canceller will consist of the undesired signal portions only. Similarly, when an optical density ratio that corresponds to the arterial oxygen saturation is selected (Case III), the reference signal only contains noise portions. Therefore, the output of the adaptive noise canceller will consist of the desired signal portions only.

$I_{rd} = S_{rd} + N_{rd}$	$I_{ir} = S_{ir} + N_{ir}$	
$S_{rd} = r_a S_{ir}$	$N_{rd} = r_v N_{ir}$	<p>r: optical density ratio</p> <p>r_a: arterial optical density ratio</p> <p>r_v: venous optical density ratio</p>
Reference Signal: $N'(r) = I_{rd} - r I_{ir}$		
Case I: $r \neq r_a, r_v$	$N'(r) = (r_a - r) S_{ir} + (r_v - r) N_{ir}$	
Case II: $r = r_v$	$N'(r_v) = (r_a - r_v) S_{ir}$	
Case III: $r = r_a$	$N'(r_a) = (r_v - r_a) N_{ir}$	

For each selected value of the optical density ratio, the corresponding reference signal is calculated and subsequently processed through an adaptive noise canceller.

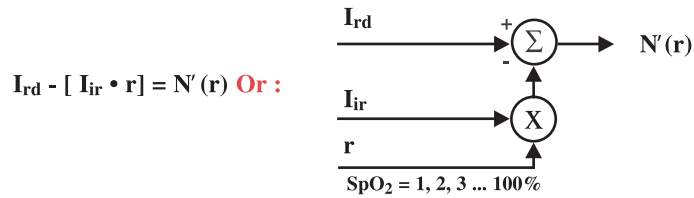

When the selected value for the optical density ratio does not correspond to either the arterial or the venous oxygen saturation (Case I), the corresponding output signal will contain little power. When the selected value for the optical density corresponds to either the venous oxygen saturation (Case II) or the arterial oxygen saturation (Case III), the output signal will contain significant output power.

The power output of the adaptive noise canceller represents the probability that the selected optical density ratio, or its corresponding saturation value, is present in the physiologic signal. The output power or probability value is plotted for a series of consecutive ratio values generating the DST transform. During periods of no motion, a singular peak is generated in the DST transform corresponding to the arterial oxygen saturation.

The more interesting example occurs during periods of motion when multiple peaks in the DST transform may be generated. Representative examples with sample waveform data are shown in the next section.

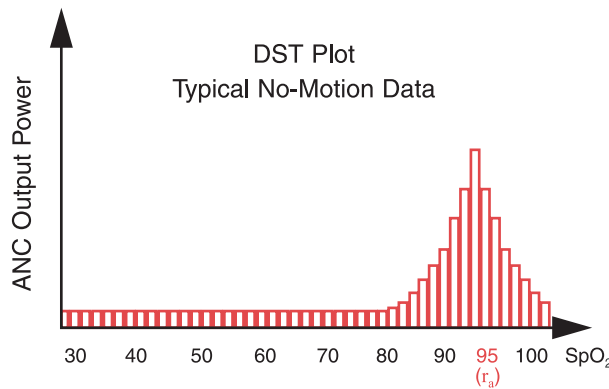

In summary, the procedure for determining the arterial oxygen saturation utilizing Masimo SET processing is as follows:

- 1) Sweep all optical density ratios that correspond to oxygen saturations of 1% to 100%.
- 2) Compute the reference signal for each optical density ratio.
- 3) Measure the output power of the adaptive noise canceller for each reference signal.
- 4) Identify the appropriate peak in the DST transform that corresponds to the arterial oxygen saturation (largest SpO₂ value).

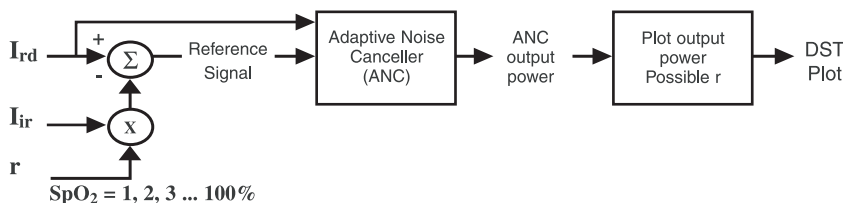

The above procedure demonstrates another important feature of Masimo SET pulse oximetry. It is able to calculate the arterial oxygen saturation without first extracting or determining discrete pulses in the physiologic data. For Masimo SET processing, the saturation algorithm is independent of the pulse rate algorithm. This is a significant distinction between Masimo SET systems and conventional pulse oximetry systems where the recognition of a clean pulse is a prerequisite for the calculation of accurate arterial oxygen saturation. Another advantage of Masimo SET technology is that it can monitor arterial oxygen saturation and pulse rate even if the motion starts before the pulse oximeter is turned on. It does not require clean data during instrument start-up.

DISCRETE SATURATION TRANSFORM EXAMPLE

In Figure A, a noise cancellation process for a selected optical density ratio corresponding to an oxygen saturation of 36% (Case I) is shown. For an SpO₂ of 36%, the calculated reference signal (shown in purple) is substantially similar to the physiologic signal due to red light (shown in red). These signals being similar effectively cancel each other within the adaptive noise canceller, yielding an output signal with little power content in the DST transform.

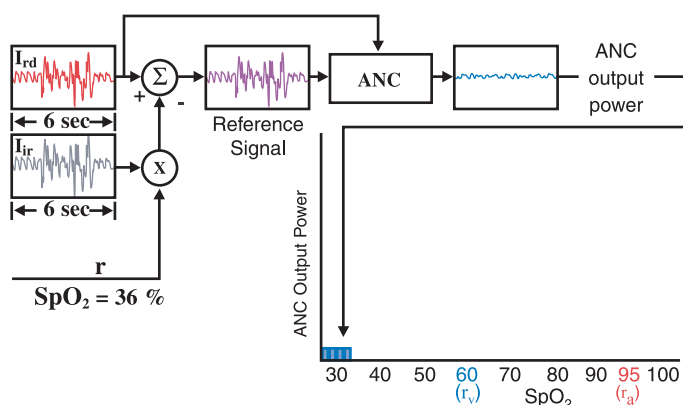

Figure A: “During Motion” DST plot at SpO₂ of 36%

In Figure B, a noise cancellation process for another optical density ratio corresponding to an oxygen saturation of 60% (Case II) is shown. As is apparent, the reference signal (shown in red) looks quite different than the physiologic signal due to red light (shown in red). This yields an output signal with significant power content in the DST transform since the noise portion is not cancelled like the example in Figure A.

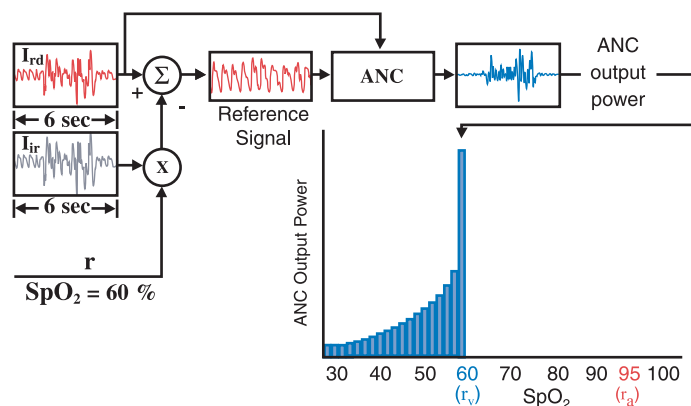

Figure B: “During Motion” DST plot at SpO₂ of 60%

In Figure C, a noise cancellation process for another optical density ratio corresponding to an oxygen saturation of 95% (Case III) is shown. In this particular instance, the reference signal is truly the noise reference. As is apparent, the noise reference (shown in blue) looks quite different from the physiologic signal due to red light (shown in red). This yields an output signal with significant power content in the DST transform since the signal portion is not cancelled like the examples in Figure A.

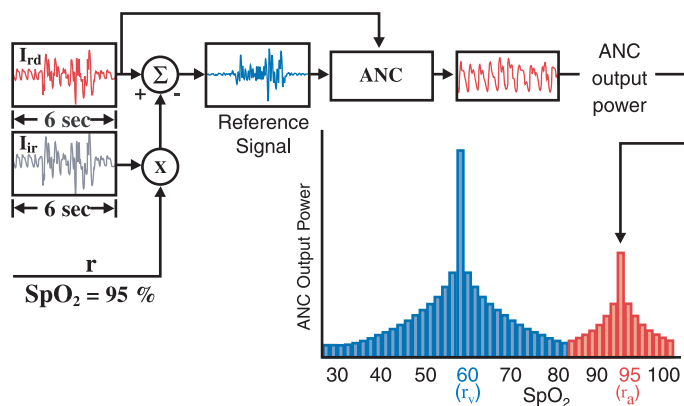

Figure C: “During Motion” DST plot at SpO₂ of 95%

REFERENCES

1. Eichhorn JH. Pulse oximetry as a standard of practice in anesthesia. *Anesthesiology*. 1993 Mar;78(3):423-6.
2. Moller JT, Pedersen T, Rasmussen LS, Jensen PF, Pedersen BD, Ravlo O, Rasmussen NH, Espersen K, Johannessen NW, Cooper JB, et al. Randomized evaluation of pulse oximetry in 20,802 patients: I. Design, demography, pulse oximetry failure rate, and overall complication rate. *Anesthesiology*. 1993 Mar;78(3):436-44.
3. Swan HJC. Retrieved July 16, 2007 from <http://www.masimo.com/cpub/testimony.htm>
4. SpO₂ Monitors with OXISMART® Advanced Signal Processing and Alarm Management Technology Pulse Oximetry Note Number 9.